

Motor frames



Lattoflex 283/383/983

Lattoflex 283-QZ/383-QZ/983-QZ

3-Motorers

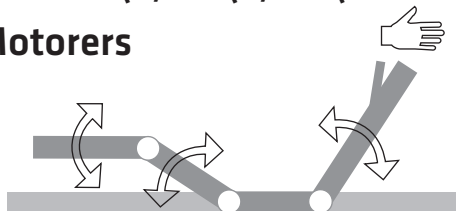

Lattoflex 284/384/984

4-Motorers

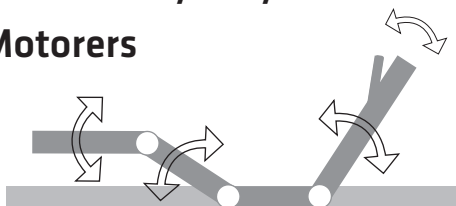

Installation and operating instructions

Important document. Please keep in a safe place.

Here you can find more information, details and videos about your product. Digital operating instructions:



www.lattoflex.com/service/x83-84

lattoflex®

Installation and operation

1 Placing in a bed

Please heed the necessary space for the adjustable frame parts, e.g. in rooms with inclined roofs, superstructures over the bed or padded head sections. An installation depth of approx. 14 cm (floor clearance) is needed in the substructure for the adjustment mechanism and drive system.

Please always heed the spacing of the back part with its motorised adjustment, to the head part of the bed. There should be spacing of at least 1.5 cm here when the bed is laid flat. To rule out any unintentional slipping, frame can be screwed to the bed at the pre-drilled points in the metal substructure.

Side support sections must not exceed 4 cm in width (middle frame 8 cm). The motor frame must always fit in the bed without any tension.

For beds with triangular supports (leg length max. 15 cm), please use the „Extension elements“ installation kit (available as accessory). For a stable bed structure, we always recommend a supporting point in the middle of the bed for triangular supports.

2 Insert version QZ in cross-frame beds

Dimension a = 29 - 37 cm: Insert directly.

Dimension a = 12 - 29 cm: Use extension elements QZ (order separately).

Version QZ without extension elements

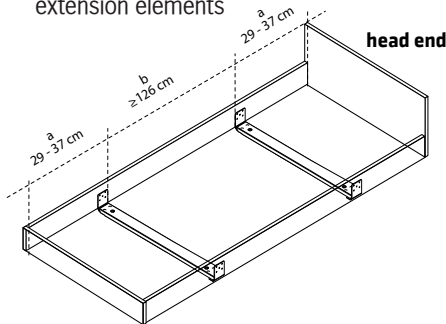

Version QZ with extension elements

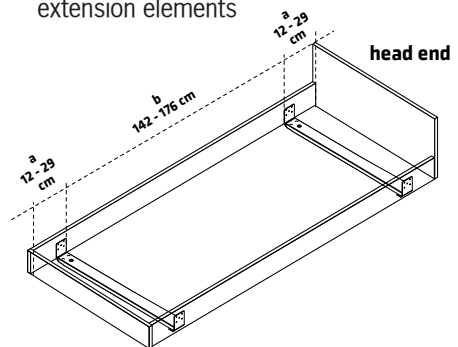

3 Mattress holder

Attach the supplied holder at the foot end. The plastic clamps are premounted.

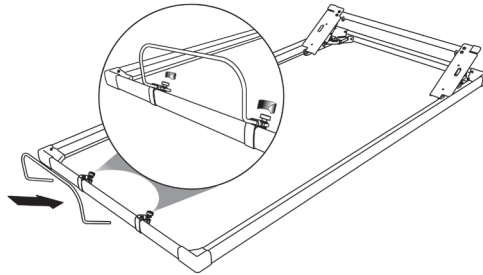

4 Connection and commissioning

Please proceed as follows to commission your motor frame:

- 1 Transport protection: Remove the velcro fastenings and the card-boards under the frame.
- 2 Hinge up the foot part of the frame, access to the black fabric pocket.
- 3 Unpack remote control and insert batteries.
- 4 Unpack control box and power adapter.
- 5 Control box can be pushed onto the calf motor at the side.

- 6 Keep remote control at the ready!
Connect power adapter to the control box and to the mains
- 7 As soon as the control has power, press any button on the remote control within 30 seconds (Plug & Connect function). The remote control has now been configured to this motor frame.

If the configuration (“teaching”) was not successful, the light in the button flashes alternately with the status LED. In this case, please press the teach button on the control box.

Adjust the settings

Use the various “up” and “down” buttons to adjust your frame. The corresponding drive moves as long as you press and hold a button. In the 3-motor version, the two top buttons (head adjustment) do not have a function.

Press  to turn the integrated torch on.

Press  to turn the underbed lighting on and off again (optional accessory).

Press the  buttons to activate your favourite settings.

Please press and hold the  button to reset all drives to zero.

Save your favourite positions

- 1 Adjust the frame to the required position.
- 2 Press the  button briefly 3 times.
- 3 Then press one of the buttons M1 - M3 immediately.

The current position is now allocated to the corresponding M-button and can be activated accordingly

Special parallel function

If necessary, two motor frames can be controlled at the same time with one remote control. To use this function for a double bed, take the remote control that has already been configured and proceed with manual configuration („teaching”) at the second motor frame. This only refers to simultaneous control.

5 Safty instructions

Do not climb on the frame when it is being adjusted and when it is raised. The frame is designed so that it normally poses no risk of getting clamped or crushed during operation. Even so, please make sure that there is nobody, in particular no child, under the frame or in a position to reach into the mechanism when raising or lowering the frame. Lattoflex 283/284 to 983/984 are inlay frames for bed structures.

They are only intended for use according to the conditions stated in these instructions and only for domestic use. Make sure that the

Manual teaching after initial commissioning

- 1 Press teach button on the control box; white LED lights up.
- 2 Press the buttons “Head up” and “Head down” at the same time. The white LED goes off again.

The remote control has now been configured to this motor frame.

Different loads can result in different settings. The positions saved for M1, M2 and M3 before changing over to parallel operation remain saved individually for each frame and cannot be called up jointly with a remote control. Only the UP und DOWN buttons can be used appropriately in parallel operation.

cables are never clamped, placed over sharp edges or crushed between moving parts of the frame. Only use original parts to replace damaged connection leads. Shortening the support beams or dismantling attachment parts poses a risk of damage.

Do not store any items under the frame. Bedding in particular can be damaged by the motors.